

Stand-alone PV System Designing for Small Market

Objective

- Design a stand-alone PV system for a small market
 - Select a market
 - Load analysis
 - Consider multiple solution
 - PV design
 - Economic analysis
- **CO # 4 Design simple solar photovoltaic systems.**
- **CO # 5 Calculate the cost of energy produced from renewable sources.**

Load Analysis of selected fish market

Shop	50W LED	40W LED	60W Fan	Hours/day [Approximately]	Total Watts	Total Energy/day (Wh/day)
1	1	2	1	5	190	950
2	1	2	1	5	190	950
3	1	1	1	5	150	750
4	1	2	1	5	190	950
5	1	1	1	5	150	750
6	1	2	1	5	190	950
7	1	2	1	5	190	950
8	1	2	1	5	190	950
9	1	1	1	5	150	750
10	1	2	1	5	190	950
				Total =	1780	8900

↓
Maximum
AC power

System Voltage

- System Voltage Based on Limiting Current to 100 A,

$$V = P/I = 1780 \text{ Watt}/100 \text{ A} = 17.8 \text{ V}$$

System voltage should be greater than 17.8 V,

So, the system voltage is 24 Volts.

[Typical lead-acid battery is 12V]

Inverter

Smarten Superb 2500 VA	Microtek PWM PCU 2250 VA
MPPT Technology	PWM Technology
Rated Power : 2000 Watt	Rated Power : 1800 Watt
Input voltage : 24 volts	Input voltage : 24 volts
Output voltage : 220 V	Output voltage : 220 V
Output frequency : 50 Hz	Output frequency : 50 Hz
Max. Battery current : 50 A	Max. Battery current : 50 A
Efficiency : 98%	Efficiency : 93%
Price : 27000/= BDT	Price : 25000/= BDT
Warranty = 5 years	Warranty = 5 years

We have selected Smarten Superb 2500 VA

Battery Sizing

$$\begin{aligned}\text{Inverter DC input} &= (\text{Total energy/day})/(\text{Inverter efficiency}*\text{system voltage}) \\ &= 8900/(0.98*24) = 378.4 \text{ Ah/day @24V}\end{aligned}$$

[Peak sun hour for worst month in Dhaka = 3.96 hours]

$$\begin{aligned}\text{Storage days (95\%)} &= 9.43 - 1.9* (\text{peak sun hours})+ 0.11*(\text{peak sun hours})^2 \\ &= 3.63 \text{ days}\end{aligned}$$

$$\text{Usable battery capacity} = (3.63*378.4) = 1373.59 \text{ Ah}$$

$$\begin{aligned}\text{Nominal battery capacity} &= \text{Usable capacity} / (\text{MDOD} * \text{T,DR}) = 1373.59/(0.8*0.97) \\ &= 1770.1 \text{ Ah}\end{aligned}$$

[Typical value of MDOD = 0.8 and T,DR = 0.97]

Battery selection

Eastern	Hamko
<p>Model: 6EPB150T Capacity: 150Ah Voltage: 12V Price: 15,000 Taka Warranty: 2 years</p>	<p>Model: HPD 130 Capacity: 130Ah Voltage: 12V Price: 14,500 Taka Warranty: 1.5 years</p>
<p>No. of batteries per string, $= 24/12 = 2$</p>	<p>No. of batteries per string, $= 24/12 = 2$</p>
<p>No. of strings needed, $= 1770.1/150 = 11.80 \approx 12$</p>	<p>No. of strings needed, $= 1770.1/130 = 13.61 \approx 14$</p>

We have selected Eastern 6EPB150T

PV Sizing

$$\begin{aligned} \text{Ah}_{\text{out}} &= \text{Inverter DC input} / \text{Coulomb efficiency} \\ &= 378.4 / 0.90 = 420.4 \text{ Ah/day} \end{aligned}$$

$$\begin{aligned} \text{PV capacity} &= \text{Ah}_{\text{out}} / \text{De-rating factor} \\ &= 420.4 / 0.90 = 467.1 \text{ Ah/day} \end{aligned}$$

$$\text{Increase capacity by 25\%} = 467.1 * 1.25 = 583.88 \text{ Ah/day}$$

[Typical value of Coulomb efficiency = 0.90 and De-rating factor = 0.90]

PV selection

Microtek 260W	REC Twinpeak 2
<p>Nominal Maximum Power = 260Watts Open Circuit Voltage (Voc) = 37.60V Short Circuit Current (Isc) = 8.88A Voltage at Maximum Power (Vmp) = 31.00V Current at Maximum Power (Imp) = 8.40A 1 module needed per string</p> <p>1 module supplies, = Imp * peak sun hour = 8.40*3.96 = 33.26 Ah/day</p> <p>No. of strings = 583.88/33.26 = 17.55 ≈ 18</p> <p>Price: 11700/= BDT per module Total Price = 11700*18 = 2,10,600 BDT</p>	<p>Nominal Maximum Power = 295Watts Open Circuit Voltage (Voc) = 39V Short Circuit Current (Isc) = 9.65A Voltage at Maximum Power (Vmp) = 32.3V Current at Maximum Power (Imp) = 9.14A 1 module needed per string</p> <p>1 module supplies, = Imp * peak sun hour = 9.14*3.96 = 36.19 Ah/day</p> <p>No. of strings = 583.88/36.19 = 16.13 ≈ 17 Price: 13275/= BDT per module Total price = 13275*17 = 2,25,675/= BDT</p>

We have selected Microtek 260W

Safety

- Total load of the system 1780 W.

Voltage = 220 V

Current = $1780/220 = 8.1$ A

For the safety of the loads, we can use a 10A circuit breaker.

PV Design Block Diagram

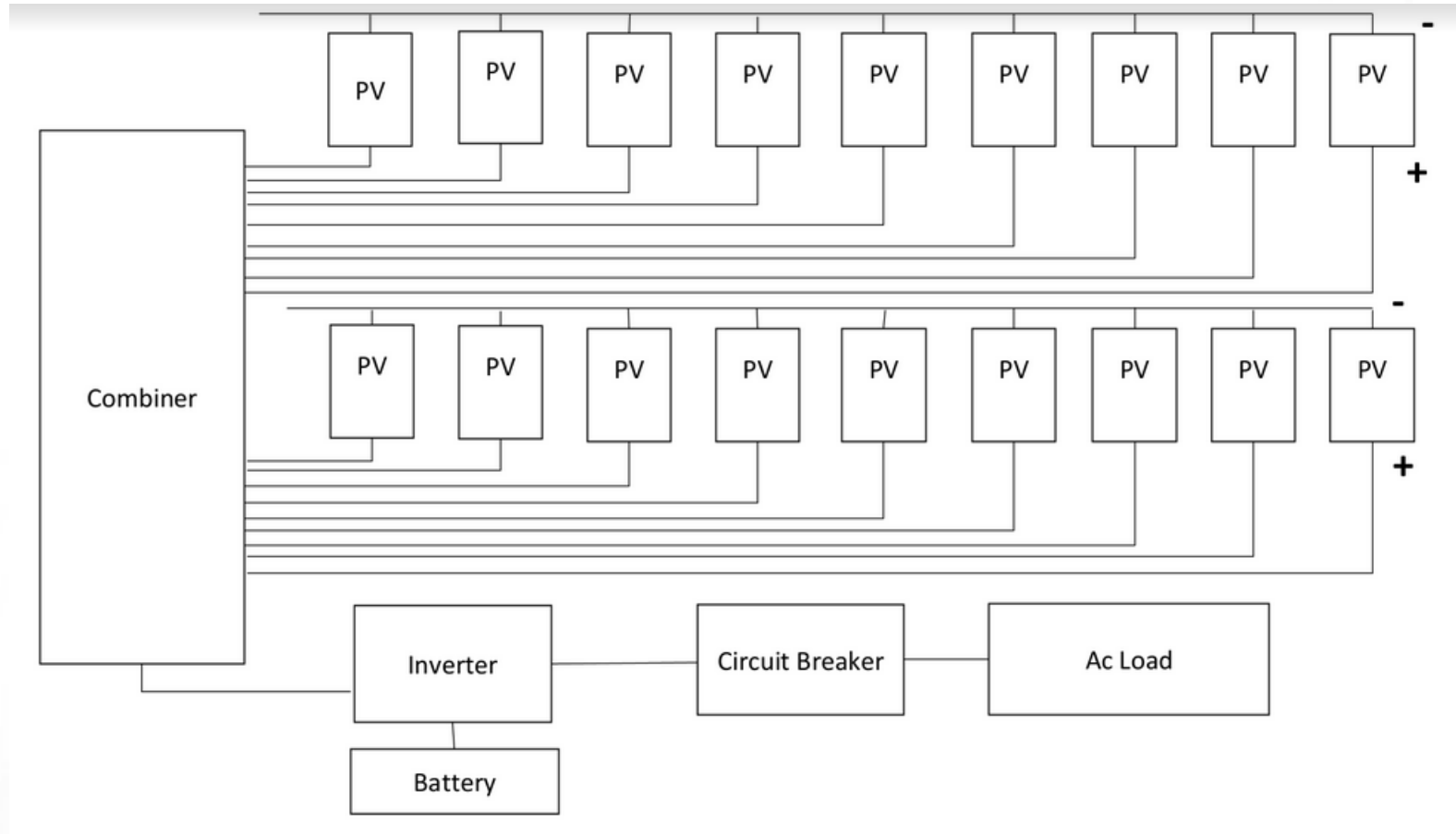

Economic Analysis

Cost of each component,

- Inverter = 27,000/=
- Battery = $15000 \times 12 \times 2 = 3,60,000$ /=
- Solar panel = 2,10,600 /=

Total fixed cost = $27000 + 360000 + 210600 = 597600$ /=

Operation and Maintenance cost = 24000TK/year

- Interest rate: 6% [1]
- Inflation rate: 6.22% [2]
- Discount rate: 7.1% [3]
- Fixed Charge Rate (FCR): 14%

Economic Analysis

Component	Years	Future value,TK, $F = P \times (1 + d)^n$
Inverter	10	53611.58
Battery	4	473653.1
Battery	8	623186.8
Battery	12	819928.8
Battery	16	1078782.8

Total future cost = 3049163.08 Tk

Economic Analysis

Average peak sun hour = 4.24 hours [4]

Capacity Factor, CF = $4.24/24 = 0.176$

Plant Capacity = $260 \times 18 = 4680 \text{ W} = 4.68 \text{ kW}$

Capital cost = Total fixed cost / Plant Capacity = $597600 / 4.68 = 127692.3 \text{ Tk/KW}$

Annualized capital cost = Total Fixed Cost \times FCR = $597600 \times 0.14 = 83,664 \text{ Tk/year}$

Energy produced per year = Plant Capacity \times 8760 \times CF = $4.68 \times 8760 \times 0.176 = 7215.4 \text{ Tk/year}$

O&M cost per year = $24000 / 7215.4 = 3.32 \text{ Tk/kWh}$

Total cost = O&M Cost + Annualized capital cost = $24000 + 83664 = 107664 \text{ Tk/year}$

Present cost of energy = Total cost / energy produced / year = $107664 / 7215.4 = 14.92 \text{ Tk/kWh}$

Economic Analysis

15

Total fixed cost with future cost = Total fixed cost + total future cost = 597600 + 3049163.08 = 3646763.08 Tk

Capital cost with future cost = Total fixed cost with future cost / plant capacity = 779222.88 tk/kW

Levelized fixed cost = (Capital cost*FCR)/(8760*CF) = (127692.3*0.14)/(8760*0.176) = 11.6 tk/kWh

Discount rate with inflation $d' = (d-e)/(1+e) = 0.008$

LF = 1.63

Levelized annual cost = O&M cost per year *LF = 3.32*1.63= 5.4 tk /kWh

Levelized cost of energy = Levelized annual cost + levelized fixed cost = 11.6+5.4 = 17 tk/kWh

Contact Details

- Inverter - M.K TECHNOLOGY

43, Dholpur, Jatrabari, Dhaka- 1204

Mobile: 01818-022196

- Battery - 103/1 Maniknoger, Motijhil

Mobile: 8801316308733

- Solar Panel – IPS Mart

645/5 Bashundhara Lane , Kazipara, Mirpur, Dhaka

Mobile: 01716767357

References

- [1] “Infrastructure Development Company Limited (IDCOL).” https://idcol.org/home/r_lending_terms (accessed Apr. 29, 2022).
- [2] “Bangladesh Inflation Rate - March 2022 Data - 1994-2021 Historical - April Forecast.” <https://tradingeconomics.com/bangladesh/inflation-cpi> (accessed Apr. 29, 2022).
- [3] “Bangladesh Bank Lending Rate, 1976 – 2022 | CEIC Data

.” <https://www.ceicdata.com/en/indicator/bangladesh/bank-lending-rate> (accessed Apr. 29, 2022).
- [4] https://www.google.com/url?sa=t&rct=j&q=&esrc=s&source=web&cd=&cad=rja&uact=8&ved=2ahUKEwiGgK_WrLj3AhViTWwGHcbpA68QFnoECA4QAw&url=http%3A%2F%2Flib.buet.ac.bd%3A8080%2Fxmlui%2Fbitstream%2Fhandle%2F123456789%2F870%2FFull%2520%2520Thesis%2520.pdf%3Fsequence%3D1%26isAllowed%3Dy&usg=AOvVaw337pQdCLrKbkOUvO5Gn1wE